



With basic weighing and a simple two-button keypad, there's no reason to settle for other brands when you can have an OHAUS!

The OHAUS CL Compact Scale is a lightweight, portable scale perfectly suited for use in industrial, jewellery and home use applications. Applications can include quality control, formulation, soil sampling, jewellery, postal weighing and dietary weighing.

Standard Features Include:

- **Superior RF Protection** – The CL is designed with superior RF protection to deliver accurate and stable results when used in production areas or near cell phones. Approvals for electrical and emissions include CE listed and FCC Class B Part 15 operation.
- **Large Weighing Platform** – The CL is designed with a large weighing platform and can adequately handle large samples including oversized letters.
- **Stackable Design with Integrated Shipping Lock** – The CL has a low profile and storage is made easy with a stackable design. The integrated load cell lock protects the weighing cell from damage during storage or transportation.

CL Series Portable Compact Scales

Specifications

Model	CL201	CL501	CL2000	CL5000
Capacity (g)	200	500	2000	5000
Readability (g)	0.1	0.1	1	1
Repeatability (Std. Dev.) (g)	0.1	0.1	1	1
Linearity (g)	± 0.1	± 0.1	± 1	± 1
Weighing Units	g, lb:oz, ozt, dwt			
Tare Range	To capacity by subtraction			
Stabilization Time	3 seconds			
Optimum Operating Temp.	18° - 25°C			
Power	3 AA batteries (included) AC adapter (optional accessory)			
Battery Life	300 hours			
Calibration	Digital calibration from keypad			
Display (cm)	LCD (1.2 high digits)			
Pan Size (cm)	12.0			
Dimensions WxHxD (cm)	14 x 4.0 x 20			
Net Weight (g)	400			

Standard Features

Easy operation with 2 clearly marked buttons, low battery indicator and auto shut-off feature to conserve battery life, mechanical and software overload protection to protect weighing cell from damage, external push button calibration (calibration masses not included). Powered by 3 "AA" batteries (included) or by optional AC adapter

Options and Accessories

Ohaus Number

Stainless steel pan	80010623
Hard carrying case	80010624
Universal power supply	46001724 (12V interchangeable plug) 46001779 (plug kit)
Calibration masses	Call Ohaus for details

Industry Leading Quality and Support

All Ohaus CL Series scales are manufactured under an ISO 9001:2000 Registered Quality Management System. Our rugged construction and stringent quality control have been hallmarks of all Ohaus products for over a century.

Outline Dimensions

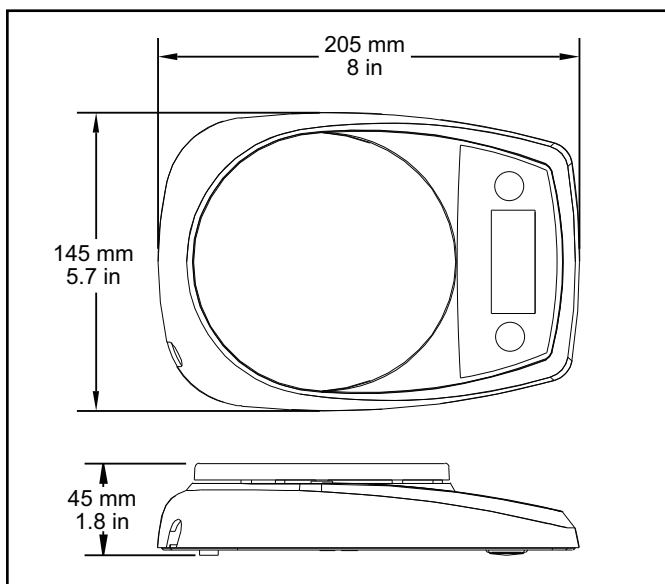

www.ohaus.com

* ISO 9001:2000
Registered Quality Management System

80774375_A © Copyright Ohaus Corporation

